

REVIEW OF THE URANIUM/PLUTONIUM CAPSULE

CLIENT: SUNDAY MIRROR

GRAHAM JOHNSON
Investigations Editor

REPORT REF N^o R2042-1A

15 MAY 2007

First Issued 15 May 2000

URANIUM/PLUTONIUM CAPSULE

The claim is that these capsules (FIGURE 1) originate from former Soviet Union military activities during the Afghanistan War. It is also claimed that many such capsules remain in and about Afghanistan and outer regions of Pakistan, with numbers ranging from many thousands of capsules to as few as a dozen or so to be found at a few separate localities.

A source in Pakistan claims that about 25 capsules could be procured immediately and, with some effort, 200 collected together within a month or so.

THE CAPSULE

The design and appearance of the capsule is very much in the style of the former Soviet Union land army equipment and stores.

The capsule forms a closed ended cylinder of 90mm diameter and 150mm overall length (approximately 3.5 by 6 inches). The volume of the capsule is approximately 1 litre.

From the photographs it is clear that the capsule outer body is a lead fabrication, sealed at top and bottom by two rolled welts, with no resealable means of accessing the contents within. Fabrication of the capsule would be relatively straightforward, not requiring any overly sophisticated tooling and equipment

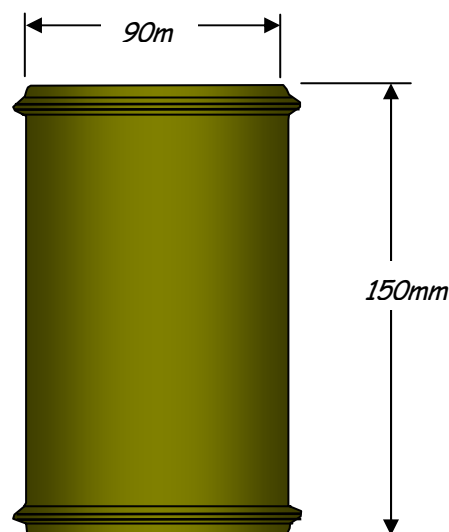

INTERPRETATION OF THE CAPSULE STENCILLING

Translating the stencilled lettering on the capsule into English and technical jargon yields:-

LINE 1

The first line is bizarre and makes little sense.

First, it cannot be an abbreviation since the **b** attached is a palatalised sound.

There are a number of possibilities if it is assumed that there is an error in the stencilling, for example:

- 1) Where the 3rd to last letter is a poorly stencilled **E**, it could read **NNO SET** where **SET** means *NETWORK* so we have **NNO NETWORK** where **NNO** is an abbreviation.
- 2) Assume that the soft sign **b** is a messed up stencil of numeral **6** then **NNO NETWORK 6** might refer to its source of manufacture or manufacturer, such as a specific Production Association.
- 3) Assuming the first **H** is a mistake, then it reads **NOSIT** which is the verb *TO BEAR* so this first line could be part of the instructions on how to handle the capsule but, if so, the leading part of the caption must be on the far side of the capsule as photographed.

LINES 2/3

The 2nd line refers to the fissile isotope uranium-235 (**U-235**) of mass 150 gram (**150 r**), although no indication is given of the enrichment of fissile U-235 isotope over the generally non-fissile U-238 isotope.

The 3rd line refers to the fissile isotope plutonium-239 (**P-239**) of mass 50 gram (**50 r**).

LINE 4

The visible segment of the 4th line reads 0.2kg (**0 , 2 Kr**) which probably relates to the total fissile content ($0.15 + 0.05 = 0.2$).

LINE 5

The visible segment of the 5th line reads 0.2kg (**0 , 2 Kr**) which probably relates to the total fissile content ($0.15 + 0.05 = 0.2$).

LINE 6

The visible segment of the 6th line reads **0 – 99?9** which could be a batch or serial number.

LINE 7

Assuming the first hidden letter of the 7th line is **I** then the line could read **GOST – 1?88 – CC(CP)** which is probably the *GOVERNMENT STANDARD* number (similar to, for example, a British Standard) for the capsule.

LINE 8

This is percentage sign (%) which would be significant if the hidden part of the text referred to the degree uranium enrichment.

LINE 9

The left side visible letters are *PS* with the right side probably referring to temperature, say the maximum temperature that the container should be subject to but, if so, the stated 1,000°C would be too high for the assumed sheet lead capsule walls, so it might be 100°C.

Giving the best possible interpretation, the capsule stencilling might then read as follows: -

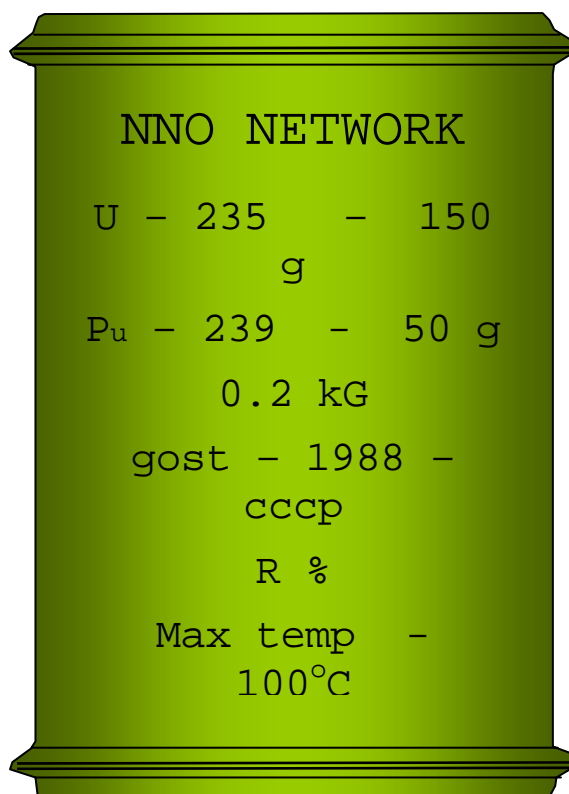

FUNCTION OF THE CAPSULE

Assuming the capsule to be genuinely sourced from the former Soviet Union and not a forged product of the local Pakistani vernacular arms industry, this is clearly a transportation package for small quantities of the fissile (radio)isotopes of uranium-235 and plutonium-239. The capsule is not, as claimed by some, part of a nuclear device or nuclear warhead.

However, why specific quantities of U and Pu (150/50) are carried and, indeed, why these two isotopes are carried together is not at all clear since there is no practicable need to consign these very small quantities together, to any nuclear device or process.¹

FORM OF THE FISSILE CONTENTS

The form of separate uranium and plutonium contents within the capsule could be either in solution (such as plutonium nitrate), in oxide forms (such as Uranium Oxide – UO_2) or in the base elemental metal form as buttons or ingots of plutonium and uranium.

In nitrate form, Pu and U concentrations range between 100 to 450 g/l so that transportation form would require a liquid volume capacity of (at least) 0.3l U and 0.1l Pu, or a total solution capacity of 0.4l. With an overall volumetric capacity of 1 litre it would be practicable for the capsule to hold the fissile material contents in soluble liquid form.

The other forms would occupy very much less volume, with the elemental metal forms occupying the least volume. In the metal form as cast 'buttons' the volume occupied would be 2.5 and 8cm³ for the plutonium and uranium contents respectively. Such buttons are cast in 20 to 40mm diameter ingots, so the buttons could be of the following dimensions:-

¹ If the uranium content was limited to natural uranium (~0.7% U-235 embedded in a matrix of 93.3% U-238) this in the ratio of 3:1 U-235/Pu could be a fast reactor fuel base. However, if so the capsule would have to have sufficient volumetric capacity to include for the U-238 content (99 x 150g or ~0.75 litre) which is very close to the maximum 1 litre capacity of indeed the capsule and, indeed, the capsule's contents would be extremely heavy (~15kg). From this reasoning, it follows that the uranium content of the capsule is most likely to be substantially enriched, possibly up to 93 to 97.5% U-235 content.

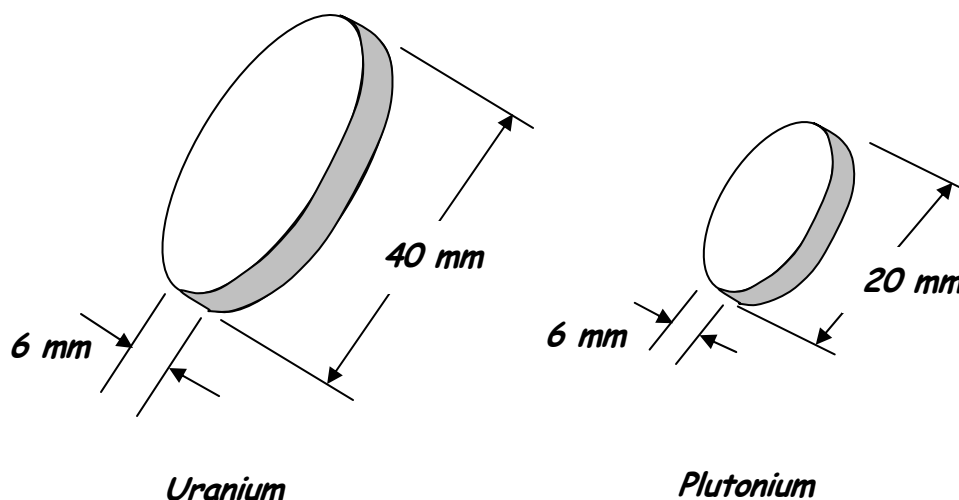

The two buttons would be separated from each other and held spatially in the centre of the capsule by a suitably inert substance, such as sand or granulated styrene, and each would be wrapped in a sealed plastic pouch - each might be gold or platinum splutter plated to inhibit corrosion.

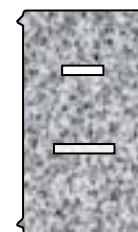

POTENTIAL USES FOR THE URANIUM/PLUTONIUM CAPSULE CONTENTS

On the assumption that the quality of the uranium/plutonium buttons is high, usually referred to as 'weapons' grade or, specifically for the enriched uranium, as 'Super Grade A', the potential application for such highly fissile materials would be for use in the fissile core of nuclear ordnance.

As such, these materials should be *safeguarded* under the terms of the International Atomic Energy Agency *Non Proliferation Treaty* of which the Federation Russia is fully signed signatory having ratified the Treaty. Pakistan (and, probably, Afghanistan) remains one of the few States that is not signatory to the Treaty.

Non-proliferation of nuclear weapons, by way of the Treaty, utilises three safeguards by which to deter the emergent nuclear armed states from crossing the nuclear arms threshold. These are, first, to prohibit the technology transfer of the design and components of the nuclear warheads; secondly, to limit the transfer of the weapons delivery systems, such as missile and targeting systems; and, thirdly, to bar the exchange of essential nuclear materials, namely uranium and plutonium.

Since nuclear weapons technology has now been established for more than half a century the technological know how need to develop nuclear ordnance is relatively

commonplace within technological and scientific circles. Moreover, much of the then highly specialised technology (synchronising circuits, etc) used in the early nuclear weapons can be found in relatively commonplace electronic components. There is a great deal of unrestricted arms trading in which nuclear capable delivery systems (aircraft, ships, missiles and artillery) are transferred from the obsolescent arsenal stocks of advanced states are transferred across the emergent states.

Because of the development of know how and the trading of nuclear capable weapons systems, etc., the only remaining effective barrier to nuclear weapons proliferation has been the bar on the transfer of fissile materials. This is because to procure for itself the relatively small quantities (a few tonnes) of fissile materials required to service an arsenal of nuclear warheads, an emerging state must construct and operate a very significant procurement programme. For uranium an enrichment works and the associated hexafluoride facility is required and, if the plutonium option is taken, an irradiated fuel reprocessing facility fed by several specialised nuclear reactor plants is required – all of these processes and associated facilities are readily detectable not just be the physical presence, but also remotely by the distinctive radionuclide signature of the plants' aerial and liquid effluent discharges.

USE OF CAPSULE CONTENTS FOR THE PROCUREMENT OF A NUCLEAR DEVICE

If a number of these capsules were to become available to terrorist groups then, given the intent of such groups, the capsule contents could be used in two ways:-

1) Radioactive Dispersal Device

This device could be deployed to disperse fission material over a large area or property and population.

In its simplest form the device would comprise one or more of intact capsules strapped to a source of flammable fuel, sufficient to melt the lead container, strip away the internal packing and ignite the plutonium/uranium contents – if in their base elemental metal form, the uranium/plutonium buttons would ignite and sustain burning at a moderately low temperature of approximately 212°C.

If the device was positioned at some elevation, say atop a high building, then wind and weather could disperse the particles and aerosols formed over a relatively large area.

Since the potency of this device would only be realised if the release particles were below the human respirable size of 10μ (1 millionth of a meter),² the efficacy of particle size reduction and subsequent dispersion area would be very much increased if a few kilograms of conventional explosive was to be used to detonate and aerosolise the plutonium.

The release and subsequent dispersion of the plutonium content of the device by far predominates the severity of consequences from the dispersion and uptake of the highly enriched uranium component of the capsule.

A gauge of the effect and longevity of a plutonium release and dispersion is given by the Minor Trials experiments at Maralinga conducted by the United Kingdom to supplement its nuclear weapons development programme in the 1960s. In these trials, plutonium was dispersed from inadvertent (contrived and non-nuclear) detonation of replica warheads to stimulate accidents involving a nuclear warhead – the plutonium was found to remain on the top surface of the ground, migrating less than a few millimetres into the topsoil over three or more years. Because of the persistence and continuing hazard presented by plutonium, all of the released plutonium must be recovered because of the immediate and longer-term health consequence.³

Particles of plutonium are a primary hazard to all forms of life when absorbed in these ways. Once in the body, plutonium particles are distributed in a manner similar to that of calcium, being carried to the bones, liver, kidneys and being deposited in the skeletal frame -plutonium is a systemic toxin commonly referred to as a 'bone-seeker'. The action of plutonium particles once deposited in the body is that the ionising alpha emissions bombard the surrounding tissue and cellular matter causing malignancy. It is generally agreed that once absorbed within the human metabolism,

² The potency of this device depends on the target population breathing in particles of plutonium oxide, which then transfer to the blood stream to be deposited in plutonium sensitive organs, particularly the skeletal frame surfaces and the gonads, so the particles have to be small enough to pass through the lung system into the blood. If, however, the disperse plutonium was to reach chlorinated water supplies (a potable water reservoir), then the presence of the chlorine renders the normally blocked gut transfer a second major uptake path.

³ Subject to detonation or fire, plutonium will aerosolise into small particles (down to below 10 to 1 micron, or smaller, in equivalent diameter) that are readily borne aloft and dispersed in the atmosphere. Plutonium-239 is an alpha radiation emitter of very persistence half-life (about 24,400 years). Alpha particles are difficult to detect and when released into the environment relatively immobile in the insoluble plutonium form. In the immediate aftermath of a nuclear weapon accident, where the high explosive has detonated or burnt, the plutonium particles are available for direct inhalation and/or absorption into the bloodstream through an open wound. In the short, medium and longer terms, plutonium particles deposited on the ground, on building and other surfaces could enter the human metabolism by ingestion and other routes or, if resuspended by disturbance, inhaled. It is generally agreed that inhalation is the most efficient route of plutonium uptake into the human metabolism. Thus, and particularly because of the persistence of plutonium-239, the risk of inhalation, ingestion and, to a limited extent, ingress via wounds remains so long as the plutonium is present in the environment.

there is very little that can be done to reduce the risk of malignancy and thus the risk of implicit health injury is effectively set at and remains sensibly constant from occurrence of uptake.

The size of the aerosolised particles of plutonium is important, particularly during the initial dispersion phase when the inhalation hazard is greatest. Generally, it is accepted that plutonium of particulate size at or smaller than 10 microns readily enter the bloodstream via inhalation. The quantity and particulate size of the plutonium release arising from a nuclear weapon accident depends on the nature and severity of the accident. Nuclear weapon accidents involving detonation and or fire will involve the release of some proportion of the plutonium.

In a high explosive detonation where all the device plutonium totally disintegrates all of the plutonium is likely to be released in aerosolised form and of this about 20% will be of respirable size. Although the results of the Maralinga trials referred to previously have never been published, it is known that the inhalation hazard extended some 17 to 35 miles during the two to three hours following the test firings and that actual ground contamination was at unacceptable levels for several miles from the test firing site. In the series of tests where the high explosive charge of replica warheads were detonated, three separate campaigns to decontaminate the land were undertaken and only a very small fraction of the plutonium was recovered.

The Maralinga Vixen B tests, with fully assembled, replica warheads, clearly demonstrate that a large tract of land would be heavily contaminated following a severe nuclear weapon accident - the nuclear weapons burning accidents at Palomares and Thule have also demonstrated this to be the case.

The United States authorities adopt simulated hazard areas for their nuclear weapon accident exercises that endorse the Maralinga inhalation and ground contamination zones. For example, the airborne plutonium dispersal assumed for high explosive detonation of a warhead comprises three zones of countermeasures, each triggered by the maximum whole body radiation dose recommended by the International Commission on Radiological Protection (ICRP).

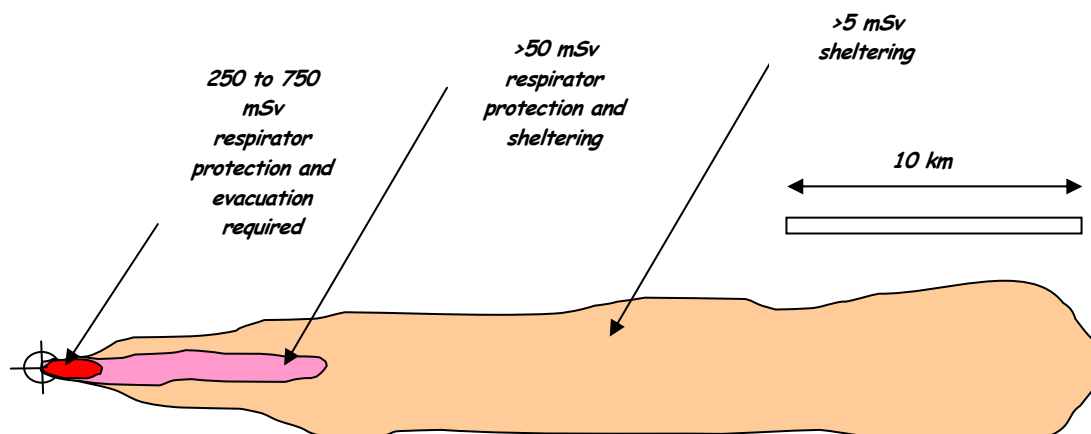

The first of these inhalation hazard zones is defined by the shadow of an overhead plume of about 1.5km length and 1km width from which evacuation of members of the public is necessary. Emergency services and other personnel engaged within this area of land require respirator protection. The second zone requires consideration of immediate evacuation of members of the public, certainly sheltering and respirator protection within a plume of about 8km length by 1km width. Members of the public remaining unprotected within the third zone, of about 130km² total area defined by a plume of 40km length by 5km width, would exceed the recommended whole body radiation dose equivalent of 5mSv and in which sheltering is recommended. These inhalation hazard zones apply so long as plutonium contaminants remain airborne, usually assumed to be for the first two, three to seven hours, or longer following the onset of detonation. Thereafter and in account of land contamination from deposition of plutonium, other zones are applied to minimise resuspension and inhalation, ingestion and control of foodstuffs, water supplies, and spread of the contaminants beyond the immediate area. The land contamination zones are similar in shape and size to the inhalation hazard zones.

Obviously, the spread and extent of the contamination zone depends on the prevailing weather conditions at the time of the release, the height and energy imparted to the radioactive plume and, obviously, the quantity of plutonium released. The above diagram is for the release of plutonium from a US nuclear warhead containing approximately 7 to 8 kg Pu and, very approximately, the extent of each of the three hazard zones will vary proportionately with the amount of plutonium released.

For example, to immobilise a segment of City of London by requiring all of the city workers to be either evacuated or, more practicably, forced to shelter in sealed up offices, the second zone would require to extend about 2 km requiring about $(2/10 \times 8 =)$ 1.6kg of plutonium or the contents of 32 capsules. However, it should be noted that the dispersion of aerosolised contaminants in urban and built-up areas is extremely difficult to predict with reliability.

Such a plutonium dispersion device is a very simple terrorist weapon. It requires no sophisticated nuclear weapons know-how or technology to assemble and, providing that the terrorist group has a small quantity of conventional explosive (5 kg) which is to be combined with 30 or so plutonium buttons that have been extracted from the capsules,⁴ it could be assembled at the site of detonation and remotely triggered. The resulting explosion would not be nuclear and it would result in very little physical

4

Providing that the plutonium buttons were of relatively high grade and had not significantly degraded with the americium daughter product, there should be little practical difficulty in extracting the Pu buttons for the capsules in the terms of the radiation shielding required. Similarly, transportation to the detonation site would be relatively straight forward, which could be accomplished in batches for assembly on site shortly before detonation – the 1.6kg of Pu cited here is below the critical mass at which a sustained, spontaneous nuclear reaction (criticality) can occur..

damage, but it would release and disperse finely divided radio-toxic plutonium over a wide area, those individuals caught within the release plume would, without respiratory protection be at risk of significant internal uptake and thus at risk of interim and longer health injury (cancers, etc).⁵

The health and economic detriment to a locality like the City of London and its workforce could be very significant. Such a device could be constructed, put in place, and triggered by a small terrorist organisation providing it had sufficient funds to purchase 30 or more capsules and transport these from Pakistan without detection.

2) Nuclear Warhead

The know-how and equipment required to construct a nuclear warhead would, almost certainly, be beyond the collective knowledge and skills of a terrorist group. However, a sub-national terrorist organisation⁶ might be able to pool together sufficient skills and facilities to construct an atomic weapon.

Both of the capsule fissile materials could be deployed. If the group chose to construct a 'gun' type device⁷ then the highly enriched uranium would be utilised, but if the group chose an 'implosion' device⁸ then either or both the capsule fissile materials could be used.

Depending upon the degree of sophistication built into either type of weapon, the fissile material requirement would range between 3.5 to 12kg Plutonium/Uranium for the implosion bomb and 10 to 15kg highly enriched uranium for the gun bomb. Reasonably, a sub national terrorist group would not be expected to have access to the most refined technology that enables advanced nuclear states to construct low fissile pit mass devices, so the fissile masses required would be at the higher end of the range, say about 10kg for either type of bomb.

So, for a single bomb, if implosion the contents of 50 capsules would be required, or if gun type 70 capsules.

⁵ There a number of thresholds proposed of the cancer causing dose of plutonium inhalation, these range from 32 to 900 micrograms of weapons grade PU

⁶ A *sub-national terrorist group* might be defined as a group that is supported and funded by a State – for example State A funds and supports a terrorist group in the neighbouring State B, providing it with expertise and facilities drawn, in this case, from its own nuclear and arms industries.

⁷ A *gun* device is whereby two just sub-critical highly enriched uranium daughter masses are propelled into a third uranium mass to form a supercritical mass of fissile material, at which exact stage an injection of neutron abundant material is triggered – called *gun* because the device comprises two stubby barrels through which the daughter masses are fired.

⁸ An implosion device is where the fissile material is cast and machined to the form of a hollow sphere (about 70mm diameter) and surrounded by a tamper, reflector and lenses of conventional high explosive. The high explosive lenses are detonated to form a coalescing shock wave that super compresses the fissile pit down to a supercritical spatial geometry, at which exact stage an injection of neutron abundant material is triggered.

Once the fissile material had been procured, it would be necessary to cast specially shaped billets and precisely machine these into either the components of the implosion fissile pit or the mass slugs of the gun type. In addition, a number of other specialised materials and components would have to be obtained and assembled⁹ to form the final assembly – the know-how for and acquisition of these associated would certainly put the manufacture of both implosion and gun type bombs beyond all but the most well resourced and facilitated sub national terrorist organisation.

The yield capability of such a nuclear weapon could, theoretically, be as high as 28 to 30kt¹⁰ but a number of factors, which is the maximum possible from an atomic fission device. It is most unlikely that even the most well prepared sub-national group could proceed to construct a thermo-nuclear fission-fusion (H-bomb) device that would provide very substantial yields (Megatons).

As well as the general resource and know-how limitations previously discussed, a yield-limiting factor would be the size and portability of the terrorist device. This is because it would not be possible to provide a design that could be carried to the detonation site in pieces for assembly at the site before detonation. Even a physically small nuclear device is relatively heavy – for example the United States army W79 nuclear tipped 8-inch diameter by 43 inch long shell of **FIGURE 3** has a mass in excess of 100kg.

So the best (or worst) that could be expected from a well resourced sub national terrorist organisation would be, for simplicity of design and construction, a ‘gun’ type device yielding up to 10 kilotons.

NUCLEAR DETONATION AND ITS CONSEQUENCES

Many aspects of a nuclear explosion differ drastically in magnitude and nature from those caused by the detonation of chemical explosives such as dynamite. This is not only because of the larger amount of energy released by a nuclear weapon but also, and more importantly, because of the much briefer time and the smaller volume within which the energy of a nuclear weapon is released.

A nuclear weapon releases 99% of its total energy in about a billionth of a second, while conventional explosive takes about a thousandth of a second to blow up. As a consequence of this and the very small amount of mass involved, not much more than

⁹ Both types of bomb will require about 20 to 30kg of conventional high explosive of very high brisance, HE detonators and a highly synchronised electronic fire circuit. To contain the initial neutron critical chain both a tamper (of depleted uranium) and a reflector (of beryllium) have to surround the pit and within the pit itself there has to be a means of initiating the abundance of neutrons to prompt the criticality, which may be achieved by a tritium initiator or, less sophisticated by a beryllium/polonium initiator.

¹⁰ kt – kiloton or 1,000 tons of equivalent TNT explosive.

a few kilograms, the vaporized materials of a nuclear weapon have a temperature of millions of degrees centigrade immediately after the completion of the fission process, compared to only a few thousand degrees for the products of a chemical explosion.

This is crucially important, because how energy partitions itself inside a hot body depends on the body's temperature. At relatively low temperatures of a few thousand degrees, most of the energy goes into the motion of the atoms and molecules of the material, and a very small fraction is emitted as radiation. At temperatures of millions of degrees, characteristic of nuclear detonations, most of the energy goes into radiation and only a small portion goes into motion of physical matter.

While the nuclear explosion is underway, most of the energy it releases (about 80%) is in the form of kinetic energy of the fission fragments and helium atoms the process generates. But about a millionth of a second after the fission process ceases, this energy has taken three forms: Most of it is being radiated out in the form of thermal (low-energy or soft) x-rays; a small portion (about 10%) is stored as excited energy inside the newly generated nuclear fragments; and the remaining energy is in the form of kinetic energy of the weapon debris, the vaporized remains of the bomb and the products of the nuclear processes, gamma rays, neutrons, and fission fragments.

The difference in the temperatures created by a chemical and a nuclear explosion has one more very important consequence. At the low temperatures of a chemical detonation the radiation that leaves the explosion is in the form of visible light and infrared radiation or heat, but at the high temperatures of a nuclear explosion the emitted radiation is in the form of thermal x-rays. Even though the neutrons and gamma rays take up no more than 5% of the energy generated by the nuclear explosion, they cause a number of serious effects, such as the electromagnetic pulse, and the prompt nuclear radiation which is lethal to humans. The excitation energy stored inside the nuclear by-products of the explosion eventually manifests itself as the lethal radioactive fallout that accompanies nuclear explosions on the ground.

Here it is assumed that the terrorist bomb is to be detonated at maximum height, for example atop a high building such as London's Telecom Tower – this will be considered to be a low altitude atmospheric explosion.

When a nuclear weapon explodes in the atmosphere, about half of the energy initially emitted as x-ray radiation transforms itself, within a few milliseconds, into kinetic energy of the air molecules through the interaction of the x-rays with the atmosphere.¹¹ The collective motion of these molecules away from the point of detonation is one

¹¹ The remaining energy escapes as thermal radiation.

cause of the blast that follows an explosion. Much of the kinetic energy of the escaping nuclei and other atomic fragments also eventually contributes to the blast.

So about a minute after the detonation, about 50% of the total explosive energy is in the form of a giant blast wave, about 40-45% is in the form of thermal radiation, and the rest, 5-10%, is stored in excited nuclei.

Thermal Radiation

Thermal radiation, which is one of the most devastating aspects of a nuclear explosion, consists of photons-packets of low-frequency waves (infrared, visible, and even ultra-violet waves) each of which carries little energy. The effects of thermal radiation on living beings and the environment depend on three properties of the source of the radiation: its intensity, its temperature, and the length of time the radiation is emitted by the source.

In general, the thermal damage is proportional to the yield of the weapon. The amount of thermal radiation an object receives depends on a number of factors, including distance of the receptor from the centre of detonation. The radiation emitted from a detonating nuclear weapon spreads out uniformly in all directions. As the energy radiates over a larger and larger area, its intensity dissipates. Furthermore, as the thermal radiation travels through the atmosphere, it is absorbed by air molecules and dust, and its intensity is additionally reduced. Less and less radiation is left to do damage the greater the distance from the centre of detonation. There is also varying attenuation depending on the weather conditions with, obviously, the heat from a nuclear detonation travelling much farther in the clear, crisp air of winter weather than in fog or rain.

So the thermal damage from nuclear detonation depends not only on distance but also on the prevailing weather conditions.

A single 10kt device will generate about 1,000 million million calories ($1250 \cdot 10^{12}$) at the centre of detonation and this will dissipate with the inverse square of distance ($E/(4\pi R^2)$) so at 2km distant the thermal radiation received is 2.5 cal/cm² (about 10 Watts for 1 second), nearer the centre at 1km about 10 c/cm² at which individuals will suffer second and third degree burns, at about 0.5km (500m) the 40 c/cm² would be sufficient to ignite most flammable materials and would be at the fringe of the area where materials would melt and further in, at say 200m, materials would evaporate.

Shock Wave

Much of the remaining 50% of the detonation energy is dissipated as an atmospheric shock or blast wave.

First, a large fraction of the original energy of the weapon initially starts out as x-rays, the less energetic of which called "soft") are absorbed by the air around the detonation after they have travelled only a few centimeters. As a result the layer of air that has absorbed them becomes very hot with the air molecules assuming a great deal of kinetic energy and move about quite violently. Those that happen to be moving outward toward the undisturbed air farther away from the detonation collide with the slower molecules of the cool air and in turn give them additional kinetic energy. This kinetic energy transfer process cascades to the end result that some tens of millionths of a second after the detonation, a very large number of air molecules are rushing away from the point of explosion, forming a shock wave moving at supersonic speeds.

This cascading motion forms a wall of compressed air crushing and sweeping everything in its way.

This is the blast shock associated with all explosions but nuclear detonations have an added dimension.

Supplementing the formation of the shock wave is the vaporised weapon debris that is moving out in all directions away from the point of detonation. As the air that had been heated by the x-rays engulfs more and more undisturbed air in the vicinity of the explosion, it cools down and the rate of expansion slows. Eventually, the weapons debris catches up with the shock wave and adds its energy by colliding with the air molecules, to the outward push of the expanding front.

As the shockwave moves outward, it also sweeps over everything in its path. Thus an object experiences two forms of pressure from the shock wave: a downward pressure, like a static crushing force, which is called "static overpressure," and a pressure resulting from the air ahead of the shock wave being stopped by the intervening object, which is called "dynamic overpressure."

Dynamic over-pressure is caused by the hurricane-force winds that accompany the shock front as it moves out from the point of detonation. Since the amount of radiation which is created by a detonation, and which subsequently heats the air causing the shock front, is proportional to the yield of the weapon, it follows that the pressure generated will be proportional to the overall energy yield of the bomb.

The pressure, of course, also varies with distance from the point of detonation. The closer to the explosion, the higher the pressure. The amount of pressure can be calculated according to the yield of the weapon and the distance from it from the empirical formulae $P = 16.4Y/R^3$, where Y is the yield in Megatons and R is in nautical miles (1.853km) and from this the wind or blast velocity can be determined. For example, at 1km the static overpressure would be a little over 1 lbf/in², at 0.75km would be 3lbf/in² with the additional dynamic pressure of about 0.5lbf/in² with a wind velocity of 120mph, and at 0.5km would be 9lbf/in² with the additional dynamic pressure of about 2lbf/in² with a wind velocity of 290mph.

Brick built structures will collapse at 3 to 5 lbf/in², trees will uproot in the following winds of a 3 to 4 lbf/in² overpressure, window panes and light panels will shatter and rip away at 5 lbf/in², and concrete and steel structures will be stripped down the skeletal frames at an overpressure of 10 lbf/in². Humans subject to overpressures suffer injuries to the lungs (at and above 10 lbf/in²), eardrum rupturing at 5 lbf/in² and, more probable death and injury by being thrown about and against walls and the like, and being sprayed with glass shards from shattering windows.¹²

In this case, the 10kt device mounted atop the GPO tower in London would impart major damage and human casualties to those individuals caught within buildings and in the open within a radius of 0.5km, further afield up to 0.75km a substantial number of individuals in the open and within the outer rooms of buildings would be at risk of flying debris and shards of glass.

The simultaneous detonation of four or more such devices, spaced at about 0.5km apart might be just sufficient to generate conditions conducive to creating a localised firestorm which would increase the damage area and severity significantly.

OTHER FATAL AND INJURIOUS EFFECTS

Other injurious and potentially fatal effects include the exposure to fast or prompt neutrons generated by the nuclear fission process, which are generally very active within 500m of the centre of detonation, although much absorbed and shielded by building structures; and, in the aftermath of the detonation longer term exposure from contaminated surfaces from the immediate fall-out of fission products from the detonation.

The fatalities, interim and longer-term health detriment of these effects are not considered further here.

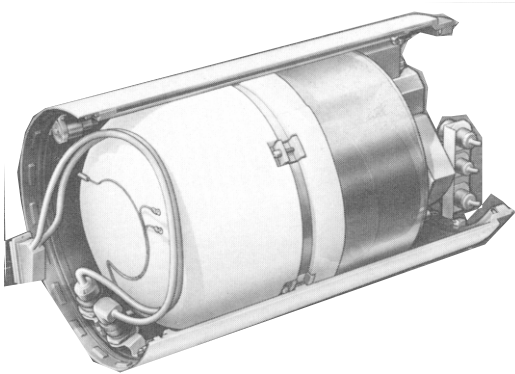
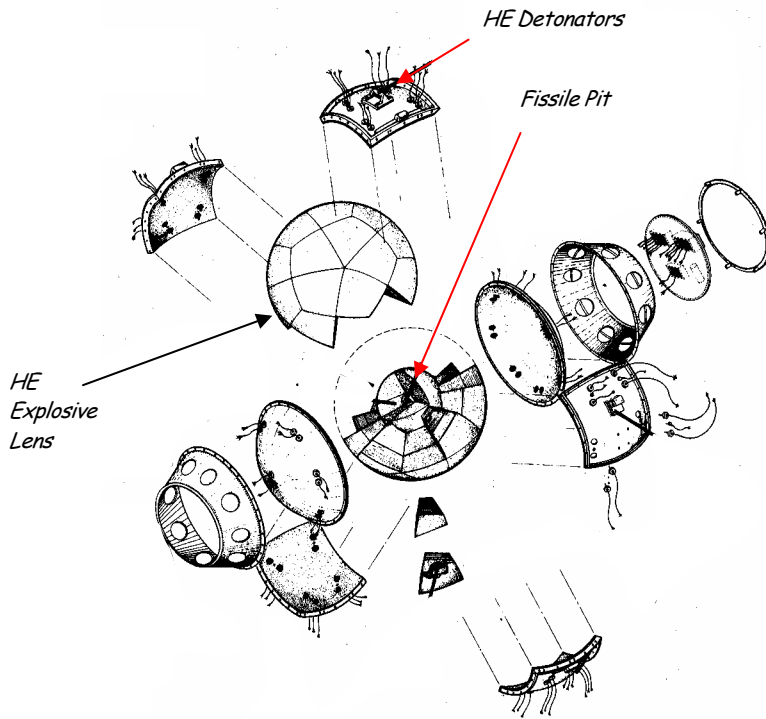

FIGURE 1 BASIC COMPONENTS OF AN IMPLOSION NUCLEAR WARHEAD AND (BELOW)
A MODERN UNITED STATES W81 WARHEAD OF 2 TO 4KT YIELD OF
APPROXIMATELY 400MM DIAMETR AND 600MM LENGTH OVERALL

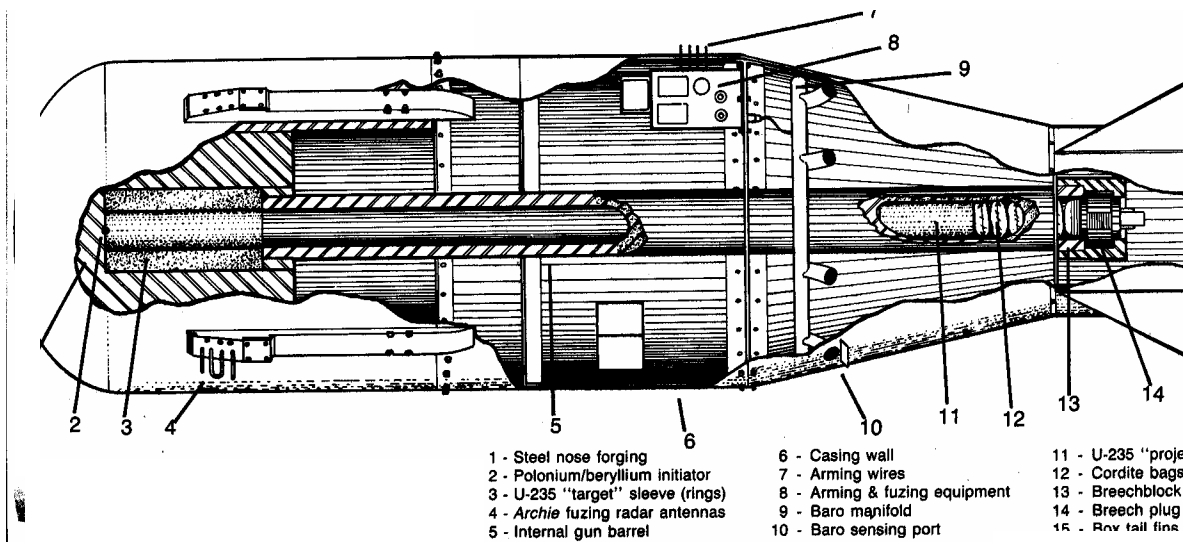

FIGURE 2 SECTION THROUGH LITTLE BOY THAT YIELDED 15 KT AT HIROSHIMA

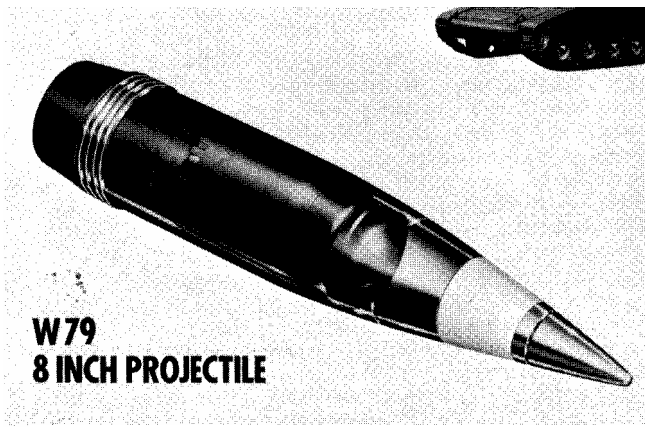

FIGURE 3 8 INCH DIAMETER W79 ARTILLERY SHELL OF 1 TO 10KT YIELD